

Plug-in Type RF Control Module



09.09RF.04735

Important: Read All Instructions Prior to Installation

Function introduction

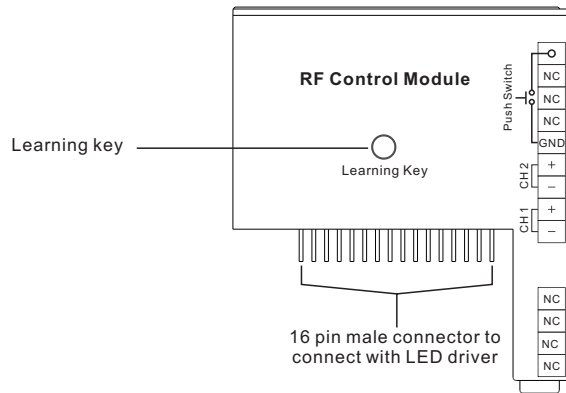

Features

- Works with plug-in control module intelligent LED driver
- Built-in RF wireless/PUSH LV dimming interface, radio frequency: 868/869.5/434/916.5MHz
- Receives RF wireless signal
- Enables to control single color and tunable white LED
- Easy to pair to RF remotes and mobile devices with learning key
- Can be compatible with a variety of RF remote controls
- Can be WiFi controlled via APP installed on IOS and Android systems
- Signal transmission distance can be up to 30 meters indoor

Safety & Warnings

- DO NOT assembly the control module with power applied to the LED driver.
- DO NOT expose the module to moisture.
- DO NOT change the control module within 1 minute after powering off the driver to avoid burning-out.

Operation

1.Assemble the control module

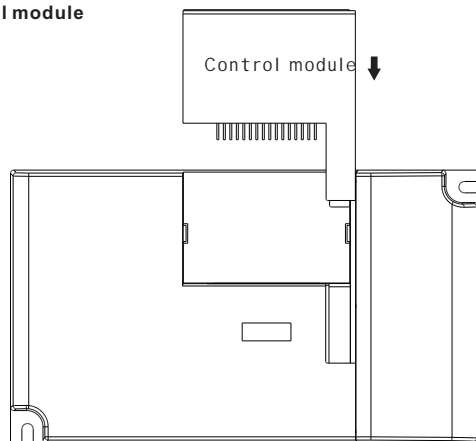

2.LED Driver Wiring:

Once the control module is assembled to the LED driver, do wiring of LED driver according to the wiring diagram.

Pair to RF sender with learning key:

1. Connect and wire up the RF receiver correctly, power on.
2. Click on/off button of the remote/panel to turn on it → Click "Learning" key on the receiver → Click a zone number (ignore this step if the remote/panel has only 1 zone) → Touch the color wheel/slider (click any button except on/off and zone buttons if the remote has no color wheel/slider) → LED lights connected with the receiver will blink to indicate successful pairing to the selected zone

Note: one receiver can be paired with max 8 remote controls.

Pairing to RF sender without learning key (Applicable to RF senders with color wheel):

1. Pairing to RF remotes which have color wheel (single color): power off and power on the receiver → turn on the remote, then click a zone number twice and press and hold it continuously and quickly within 10 seconds → LED light connected with the receiver will flash to indicate successful pairing to the selected zone.
2. Pairing to multi-zone RF touch panels which have color wheel (single color): power off and power on the receiver → turn on the panel, then click a zone number three times and press and hold it continuously and quickly within 10 seconds → LED light connected with the receiver will flash to indicate successful pairing to the selected zone.

Note: RF remotes without color wheel, single zone RF touch panels with color wheel, and RF touch panels without color wheel do not have this function.

Pairing to RF sender without learning key (Applicable to all compatible RF senders):

Re-power on the receiver three times continuously to set it into pairing status → Within 15 seconds, click on/off button of the remote/panel to turn on it → Click a zone number (ignore this step if the remote/panel has only 1 zone) → Touch the color wheel/slider (click any button except on/off and zone buttons if the remote has no color wheel/slider) → LED lights connected with the receiver will blink to indicate successful pairing to the selected zone

Delete pairing with learning key:

1. Wire up the RF receiver correctly, power on.
2. Press and hold down the " Learning Key" button on receiver for over 3 seconds until the connected led light on receiver flickers twice, which means well deleted.

How to stop running mode of single color LED light caused by RGBW sender interference:

1. When pairing single color LED light to a single color remote, it might be interfered and paired by nearby RGBW senders, which might control the single color light into running mode. The running mode can not be stopped by the paired single color remote or by delete pairing.
2. Then we need a remote or wall panel that has color wheel, and pair the remote or wall panel to the receiver via above mentioned pairing method "Pairing to RF sender without learning key (Applicable to RF senders with color wheel)", then touch the color wheel to stop the running mode.
3. Then delete pairing and pair the receiver to the single color remote again, it can be controlled by the remote again.

PUSH DIM:

While connected with PUSH LV, click the button to switch ON/OFF lights. Press and hold down the button to increase/decrease light intensity.

