

Connector - with TE screw terminals, for harsh applications



Product description	
BALS-Prd.-Nr	31724
EAN	4024941317245
product category (PG)	Connector TE
current (A)	63A
number of poles (P99)	3p
number of poles (P)	2P+PE
position of earth contact (H)	7 h
voltage (V)	480 up to 500V

Product description	
frequency (HZ)	50 and 60Hz
protection degree (SA)	IP67
colour code 1 (KF1)	black RAL 9005
Colour of appliance	Collar black RAL 9005, Hinged lid black RAL 9005, Bayonet ring grey RAL 7035, Cable gland grey RAL 7035, Housing cover black RAL 9005
connection design (AT)	screw terminal as box terminal with Kontex-contact
maximum conductor size (LQ)	16,0 qmm
cable entry (KE)	Cable gland
Height	251mm
Width	110mm
Depth	115mm
material of enclosure (GM)	Polyamide
contact	The contact carrier is made of high temperature resistant material, the contacts are brass nickel plated

Additional technical properties	
	For cable diameter from 16 up to max. 36 mm, Screwless housing connection, Multi-Grip cable gland with gasket, integrated cable clamp and additional water evacuation openings

Logistics data	
Weight/pcs	0.665 kg / Piece
Packaging	Carton

Logistics data	
Content amount	5 ST
EAN	4024941835312
Length	325 mm
Width	217 mm
Height	210 mm
Weight	3.527 kg
Volume	13,588.4 ccm

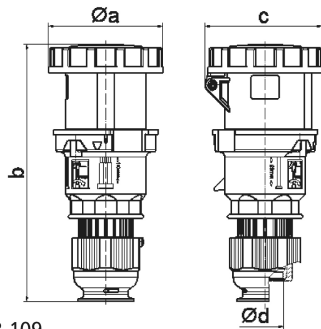

Ampere	63	63	63				
Polzahl	3	4	5				
a ø	110,0	110,0	110,0				
b	251,0	251,0	251,0				
c	113,0	113,0	113,0				
d ø	36,0	36,0	36,0				
Leiter mm ² min	6	6	6				
Leiter mm ² max	16	16	16				